

Turning a Premium Peppermill

Supplies Needed

- Blank
- Sandpaper/Finish
- 1 5/8" Forstner Drill Bit
- Drill or Drill Press
- 1 1/6" Forstner Drill Bit
- Eye and Ear Protection
- 1/4" Drill Bit

Selecting the Blank

1. Select a 2-3/4" square blank that is 1" longer than the mechanism you have selected. The overall length of the completed mill needs to be 1/8" longer than the shaft of the mill.

Mounting the Blank

1. Mount the blank between center and rough turn to about 2-1/2" in diameter (see figure 1). Layout the mill top and spigot on the blank and part them.

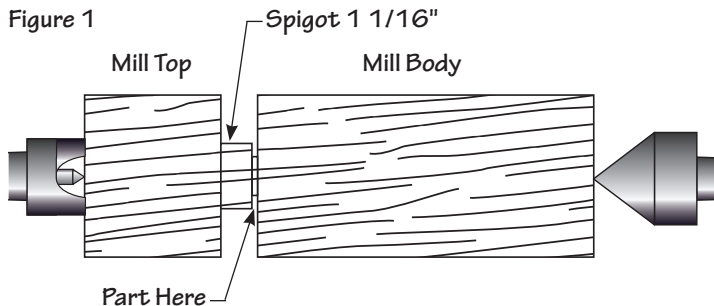

Drilling the Blank

1. Drill holes for the peppermill (see drawing).
2. Drill a 1-5/8" diameter hole 1/2" deep into the base of the mill body.
3. Drill a 1-1/16" hole the rest of the way through the mill body.
4. Drill a 1/4" hole through the mill top.

Finish Turning the Blank

1. Turn the base and top to the desired shape.
2. Turn a 1 1/6" spigot 1/2" long to fit into the top of the mill body (see drawing). Then apply your favorite finish.

Install the Mechanism

1. Install the mechanism as shown at right.

